

6 Star and 7 Star Equivalent Energy Efficient models are available for energy savings and reduced water wastage.

GAS CONTINUOUS FLOW

	RHEEM 16	RHEEM 20	RHEEM 24	RHEEM 24/7	RHEEM 27	INTERNAL 27
Model Number	874016NFZ/LFZ	874020NFZ/LFZ	A871024NFZ/LFZ	884024NFZ/LFZ	874627NFZ/LFZ	864627NFZ/LFZ
L/Min @25 C Rise	16L/Min	20L/Min	24L/Min	24L/Min	27L/Min	27L/Min
Gas Input Max.	126 Mj/Hr	153 Mj/Hr	188 Mj/Hr	162 Mj/Hr	205 Mj/Hr	205 Mj/Hr
Gas Type	NG or LPG	NG or LPG	NG or LPG	NG or LPG	NG or LPG	NG or LPG
Gas Connection	R 3/4" / 20	R 3/4" / 20	R 3/4" / 20	R 3/4" / 20	R 3/4" / 20	R 3/4" / 20
Min. Gas Supply Pressure NG/LPG	1.13 kPa/ 2.75 kPa	1.13 kPa/ 2.75 kPa	1.13 kPa/ 2.75 kPa	1.13 kPa/ 2.75 kPa	1.13 kPa/ 2.75 kPa	1.13 kPa/ 2.75 kPa
Water Pressure (kPa) Min-Max	140-1000	140-1000	140-1000	140-1000	140-1000	140 - 1000
Minimum Flow Rate	2.7L/Min	2.7L/Min	2.7L/Min	2.0 L/Min	2.0 L/Min	2.0 L/Min
Cold Water Connection	R 3/4" / 20	RP 3/4" / 20	RP 3/4" / 20	R 3/4" / 20	RP 3/4" / 20	RP 3/4" / 20
Hot Water Connection	R 3/4" / 20	RP 3/4" / 20	RP 3/4" / 20	R 3/4" / 20	RP 3/4" / 20	RP 3/4" / 20
Approx. Weight	21kg	21kg	21kg	24kg	24kg	24kg
Freeze Protection	Yes	Yes	Yes	Yes	Yes	Yes
Unit Height (mm) A	520	520	565	604	601	651
Unit Width (mm) B	350	350	350	354	351	331
Unit Depth (mm) C	163	163	205	255	226	254
Hot Water Outlet (mm) D	126	126	132	117	132	132
Gas (mm) E	125	125	92	121	127	127
Cold Water Inlet (mm) F	43	43	21	22	28	28
(mm) G	45	45	103	97	97	103
(mm) H	43	43	53	66	64	70
(mm) J	51	51	127	110	84	91
Gas Energy Rating	5.3 Stars	5.1 Stars	6 Stars	6 Stars*	6 Stars	6 Stars

CONTINUOUS FLOW ACCESSORIES PART NUMBER

Horizontal Flue Kit Side Exit	318278
Horizontal Flue Kit Rear Exit	318279
Vertical Flue Kit	318280
Recess Box - For Rheem 27L	317695
Recess Box - For Rheem 16 & 20L	317714
Recess Box - For Rheem 24L	316383
Recess Box Kit Adaptor - For Rheem 16 & 20L	317618
Pipe Cover - For Rheem 27L	317694
Pipe Cover - For Rheem 24L	316381
Pipe Cover - For Rheem 16 & 20L	317612
EZ Link Cable	290141

STANDARD TEMPERATURE CONTROLLERS

Kitchen	A299850
Bathroom 1	A299851
Bathroom 2	A299852

DELUXE TEMPERATURE CONTROLLERS

Kitchen	A299861
Bathroom 1	A299862
Bathroom 2	A299863

CONTROLLERS

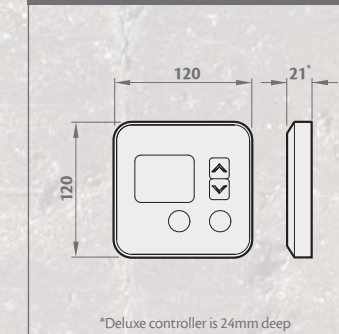

*Deluxe controller is 24mm deep

RECESS BOX

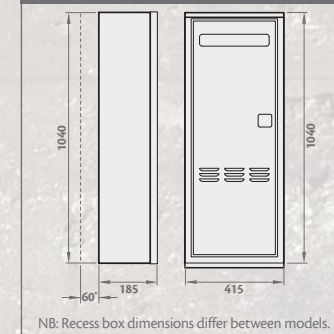

NB: Recess box dimensions differ between models.

*Rheem 24/7 is 7 Star Equivalent.

RHEEM 27 INDOOR FLUE SYSTEM

A certified Rheem coaxial flue system must be used with all Rheem 27 indoor models. There are three indoor flue kits available- Horizontal Side Exit, Horizontal Rear Exit and Vertical. Please contact your local plumber, plumbing merchant or Rheem Customer Service on 0800 657 336 to discuss the best solution for your needs. The Rheem flue system uses a twin-pipe design (one pipe inside the other); an inner pipe of stainless steel for exhaust, and an outer steel pipe for inlet air. This flue system can exhaust either through a roof or wall. (Subject to Building Regulations).

RHEEM CONTINUOUS FLOW SPECIFICATIONS

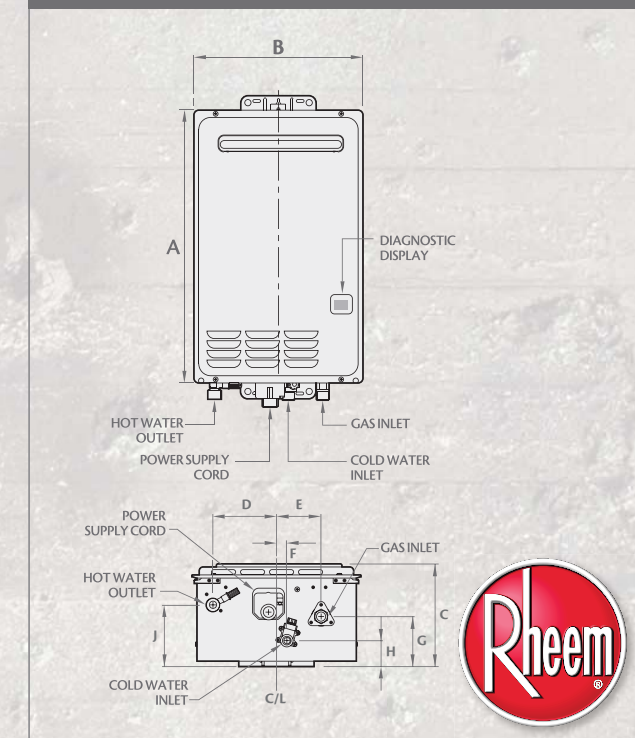

LUXURIOUS GAS CONTINUOUS HOT WATER

ELECTRIC • GAS • SOLAR • HEAT PUMP • BOILING WATER



STEADY, HOT & STRONG

INSTALL A RHEEM™

STEADY, HOT & STRONG

INSTALL A RHEEM™

www.rheem.co.nz

www.rheem.co.nz

GAS CONTINUOUS FLOW

Continuous Flow Water Heaters deliver hot water that never runs out because they heat water when you need it.¹

Generally, Rheem Continuous Flow water heaters deliver hot water that never runs out because they heat water when you need it, for as long as you need it. They work differently to traditional storage water heaters, only heating on demand rather than heating and storing water. Rheem Continuous Flow water heaters mount conveniently to the wall, taking up less space. They are ideal when space is at a premium or when hot water is used sporadically, such as a guest bathroom or distant ensuite.

Rheem Gas Continuous Flow water heaters are a technically advanced continuous flow water heating system. They meet the IQ Function standard, offering the most accurate temperature control with advanced sensors and solenoid-controlled water flow valves to mix the heated water with cold for the perfect result. It will even recall latent heat — for a much more accurate water temperature, if the unit is turned back on within five minutes of its last use.

Generally, Rheem Continuous Flow water heaters operate at higher internal temperatures to prevent damaging condensation from forming.

Patented technology, the FlameSafe® safety mechanism, ensures the safest operation possible.

In homes where there is big demand for water, or in colder areas of the South Island where the ambient water temperature is low, two units (16, 20 & 27 models only) can be linked together using the Rheem EZ-link system to deliver twice the flow (32, 40 or 54 litres per minute).

The efficient cross over point for continuous flow heating is 135 litres per day. If your home uses more than that, a Stellar Gas Storage water heater will be a more efficient water heating option.

With a wide range of capacities, there is a Rheem Continuous Flow model for every budget and family.

Rheem Continuous Flow

- Flame Safe superior safety
- Optional Temperature Controllers
- Continuous hot water
- Built-in diagnostics & operational display
- Optional exterior recess box
- IQ intelligence built-in
- EZ-Link (16, 20 & 27 models only)

Bathroom 1-2	16-27L per min	Outdoor & Indoor	Gas
--------------	----------------	------------------	-----



Models: 16, 20, 24, 27 Litres per minute available.
¹Providing gas, water and power available.

Rheem Gas Continuous Flow Range

Outdoor 27L/min*

6 Star efficiency. Solar ready options — compatible with Solar systems, without the need for any additional valves. EZ-Link compatible (flexible delivery of any volume between 32 and 54 Litres/minute). Reduced water wastage – reduced flow during start-up.

Improved Minimum Flow Start-up

The Rheem 27 boasts an economical 2 litre per minute start up rate. While some continuous flow water heaters require a minimum of up to 3 litres, the Rheem 27L reduces water wastage and compliments the installation of water efficient tap-ware.

For harsh water conditions, or even greater peace of mind, the tin-plated 27L 864027LFZ/AW (internal) and 874027LFZ/AW (external) models are recommended.



24L/min, 7 Star Equivalent

7 Star Equivalent energy efficiency. 24L/minute continuous hot water delivery. 93% Thermal Efficiency. Remote Temperature Controller options for added convenience and safety.



Outdoor 24L/min

Our most popular continuous flow water heater. 24L per/ min. Digital display for easy fault diagnosis and service. Full technical support through the Rheem National Service Network. Unique Flame Safe overheat protection system.



Indoor 27L/min

6 Star efficiency. Indoor installation e.g. Hot water cupboard, roof space or garage. Centralised installation can minimise delivery delay to hot water outlets. Minimised risk of theft.



Outdoor 16L & 20L/min

Ideal for homes which require less demand or for the holiday house or bach. Digital display for easy fault diagnosis and service. Full technical support through the Rheem National Service Network. Unique Flame Safe overheat protection system.



* Rheem 27L 874627LFZ and 862627LFZ models installed in the Christchurch City Council reticulated water supply are covered by Rheem NZ's standard warranty. Contact Rheem Customer Services on 0800 657 336 for more information on warranty conditions for other models.

Check out our EZ Guide online selection tool:
www.rheem.co.nz/selector/

WHY CHOOSE FROM THE CONTINUOUS FLOW HOT WATER RANGE?

- Never run out of hot water¹
- Range of capacities from 16 – 27Litres/Minute
- Ability to deliver up to 54L/Minute by linking two units with the Rheem EZ Link system
- Flamesafe® overheat protection
- Digital display for easy fault diagnosis and service
- Frost protected down to -20°C (Standard for all models)
- Compact size models, perfect for any location with limited space
- Full technical support through the Rheem National Service Network
- Available to suit Natural Gas or LPG
- Rheem Warranty and After Sales Network ensure expert technical advice and fast service

¹ Providing gas, water and power are available.

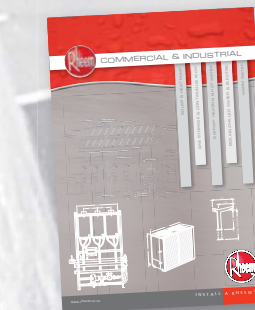

COMMERCIAL PRODUCTS

Our Commercial Continuous Flow Water Heater range includes an 82 degree model and meets all the demands expected of Rheem products — from luxury homes to the largest commercial hot water application imaginable.

For a copy of our Commercial & Industrial Solutions Guide, visit www.rheem.co.nz or call 0800 657336.

OPTIONAL RECESS BOX AVAILABLE

INSIDE

Rheem offers continuous blending which minimises cold spots and temperature fluctuations.



10 YEAR WARRANTY

Rheem offer a 10 year warranty on the heat exchanger plus a 3 year warranty on parts and labour.



6 STAR RATING

This is achieved reducing start-up water flow (less water wastage). 27L model only



In homes where there is big demand for water, or in colder areas of the South Island where the ambient water temperature is low, two units (16, 20 & 27 models only) can be linked together using the Rheem EZ-link system to deliver twice the flow (32, 40 or 54 litres per minute).



FLAMESAFE PROTECTION SYSTEM

A unique Rheem safety protection feature that automatically shuts down the Rheem Continuous Flow Water Heater should a fault occur.

